



Telecommunications



Data Centers



Industries



Renewable

TWO-WAY BUILDING AMPLIFIER 1.2GHz

AMPBLU120CA

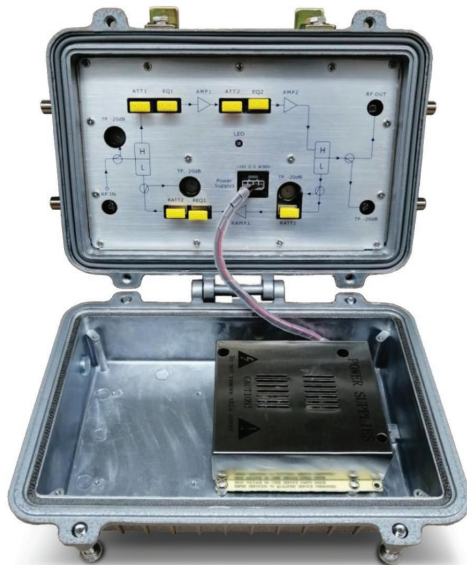

DESCRIPTION

The BLUNERY AMPBLU120CA Building Amplifier is the indicated 1.2GHz DOCSIS 3.1 bi-directional amplifier solution. Its GaAs technology allows to obtain excellent performance and flat responses in the working bands, with gains in forward greater than 35dB @ 102-1218MHz and in reverse of 24dB @ 5-85MHz. The "S / N" signal-to-noise ratio is superlative and guarantees excellent performance against CSO, CTB, XMOD, MER and BER distortions.

It has very high reliability and is very easy to use and configure.

Both the attenuation and the equalization are adjusted using standard JXP PAD 'plug-in' type attenuators, which reduces the number of plug-ins the technician must carry, as well as allowing configurations adaptable to the different installation scenarios.

The diplexers are of the plug-in type and can be easily replaced for other configurations.

MAIN FEATURES

- 1.2GHz bandwidth with protocol support DOCSIS 3.1.
- Gains greater than 35dB in direct and 24dB in reverse.
- Plug-in attenuators and equalizer modules of the type JXP PAD.
- GaAS technology.
- Low noise figure.
- Power input compatible with the networks of HFC 60/90VAC or direct connection to commercial electrical networks 110-220VAC.
- Wide operating temperature range -40 ° C / + 50 ° C.
- Protection against overvoltages and transients of 6KV.
- IP54 aluminum injection housing with mesh metallic to reduce leakage.

TWO-WAY BUILDING AMPLIFIER 1.2GHz



AMPBLU120CA

SPECIFICATIONS

AMPBLU120CA

ELECTRICAL

MAIN - FORWARD

Technology	GaAs
Work Band [MHz]	102-1218
Gain [dB]	≥ 35
Working Band Response [dB]	± 1.2 (typical: ± 1)
Test Points [dB]	-20 ± 1 relative to in or out port
Return Loss [dB]	≤ -16
Output Level [dBmV]	39/52 @102/1218MHz
Input Equalization Range [dB]	0 - 20 in 1dB steps
Input Attenuation Range [dB]	0 - 20 in 1dB steps
Interstage Equalization Range [dB]	0 - 20 in 1dB steps
Interstage Attenuation Range [dB]	0 - 20 in 1dB steps
Noise Figure [dB]	≤ 8
Distortion CTB ON 7 & 25 MHz [dB] ** see footnote 1	≤ -70
Distortion CSO ON 6 & 32 MHz [dB] ** see footnote 1	≤ -60
HUM Modulation [dB]	≤ -65
Group Delay [nSeg]	≤ 35 @3.58MHz Span

MAIN - REVERSE

Technology	GaAs
Working Band [MHz]	5 - 85
Gain [dB]	24
Working Band Response [dB]	± 0.75
Test Points "Test Points" [dB]	-20 ± 1 relative to in or out port
Return Loss [dB]	≤ -16
Output Level [dB]	46 @85MHz
Input Equalization Range [dB]	0 - 20 in 1dB steps
Output Attenuation Range [dB]	0 - 18 in 1dB steps
Output Equalization Range [dB]	0 - 20 in 1dB steps
Noise Figure [dB]	≤ 8
Distortion DTO ON 7 & 25MHz [dB] ** see footnote 2	≤ -70
Distortion DSO ON 6 & 32MHz [dB] ** see footnote 2	≤ -60
HUM Modulation [dB]	≤ -75
Group Delay [nSeg]	≤ 35 @1MHz Span

EXTENDED

Supply [VAC]	33-80 / 176-247
Power [W]	≤ 25
Overcurrent Capability [AAC]	10
Maximum Transient Protection Voltage 10 / 700uS [KV]	6

** Note 1: 72 NTSC + 111 QUAM (-6dB offset), 110dBuV / ch virtual output @ 1218MHz @ 14dB tilt

** Note 2: 13 & 19MHz 2 chnal, 106dBuV flat output, 1 port test (according with ANSI / SCTE1152011)

TWO-WAY BUILDING AMPLIFIER 1.2GHz



AMPBLU120CA

SPECIFICATIONS (continuation)

	AMPBLU120CA
OTHERS	
Connectors	F-female imperial
Protocol	DOCSIS 3.1
Attenuators / Equalizers Model	Plug-In JXP
Amplifier Output	Push-Pull
MECHANICAL	
Degree of Protection	IP54
Size: H x W x D [mm / inch]	260 x 200 x 120 / 10.24 x 7.87 x 4.72
Weight [Kg / Lbs]	2.2 / 4.85
Cabinet Material	Injected Aluminum
Termination	Aluminum
Mounting Angles Steel [mm / inches]	Circular: 7 / 0.27 diam, Oblong: 7 x 12 / 0.27 x 0.47
ENVIRONMENTAL	
Working Temperature [° C / ° F]	-40 to +50
Storage Temperature [° C / ° F]	-40 to +80
Relative Humidity - Non-Condensing [%]	5 to 95
Altitude [masl]	5000
INTERNATIONAL STANDARDS	
Safety	CE compliant
USA	ANSI / SCTE

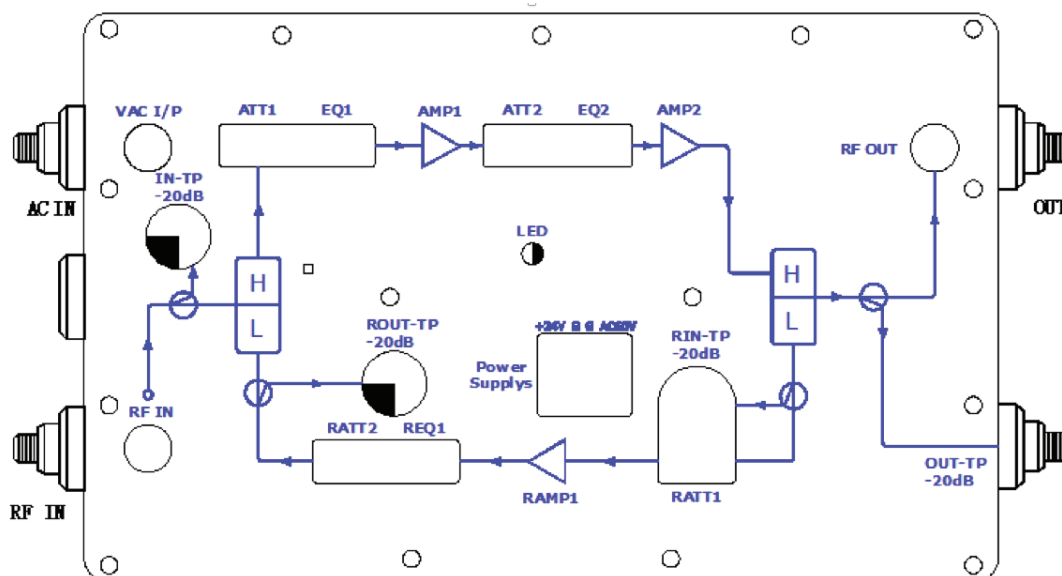

Latpower reserves the right to change product specifications and design without notice.

1014-NJUN21